

GRADALL[®]

XL 7210 V

STEEL MILL MAINTENANCE



SPECIFICATIONS

Engine

- Volvo TAD581VE, Stage 5, 5.1L diesel with SCR and DPF + DOC and uncooled EGR
- Gross Rating:** 172 hp @ 2000 rpm (128kW)
590 lb-ft @ 1100-1500 rpm (800Nm)
- Net Rating:** 152 hp @ 2000 rpm (113kW)
- Four cycle, inline four cylinder, liquid cooled
- Variable viscous fan clutch system
- Vertical stacked hydraulic oil cooler, charge air cooler and radiator
- Vertical canister style lube filter attached to engine
- Vertical canister style main fuel filter and fuel/water separation with manual feed pump attached to engine
- Water in fuel indicator and alarm
- Block heater

- Maximum slope:** 30°
- 24 volt starter
 - 100 amp alternator
 - Two SAE #C31-S 1000 CCA batteries
 - Two-stage dry type air cleaner with centrifugal pre-cleaner and safety element
 - Vacuator valve and service indicator

Fuel tank capacity: 82 gallons (310 L)

Operator Cab

- All-weather cab
- Tinted safety glass windows
- Acoustical lining
- Four-way adjustable seat
- AM/FM radio
- Filtered fresh air heater
- Defroster
- Air conditioner
- Heat-resistant glass in front window
- Rearview mirror on left side
- Seat belt
- Swing lights
- Camera system with three external cameras

Controls

- Two electronic joysticks (hoist and bucket, telescope and swing)
- One rocker switch (tilt) control
- Joysticks on arm pods
- Quick change joystick pattern switch on instrument panel

- Self-centering joysticks; When controls are released, power for movement disengages and swing and tilt brake sets automatically
- Two electric foot pedals (with handles) control crawler travel speed and direction, crawler steering and braking
- Toggle switch on arm pod allows selection of two crawler speed ranges

Engine Controls and Instrumentation

- Key operated ignition/starter switch, throttle and main battery disconnect switch
- Air cleaner condition indicator
- Electronic monitor indicates fuel level, low battery charge, lube oil pressure, high coolant temperature, engine rpm and engine hours with shutdown protocol
- Fuel saving feature automatically sends engine rpm to idle when control circuits are in neutral for seven seconds

Boom

- Two piece triangular telescoping boom
- Adjustable boom rollers with eccentric shafts
- 360° continuous boom tilt
- 105° boom pivot angle
- Auxiliary hydraulics

Hydraulic System

- Pumps**
- One load-sensing axial piston pump oil flow 0-110 gpm (0-416 L/min)
 - Pilot gear pump 6 gpm (23 L/min)

- System Monitor**
- Electronic monitor in cab indicates:
 - Low hydraulic fluid level with shutdown
 - High hydraulic fluid temperature
 - System working pressure
 - System pilot pressure

SYSTEM SPECIFICATIONS

- Four Cylinders**
- One tool: 5.0" ID, 3.0" rod, (127 mm x 76 mm), 25.9" (658 mm) stroke
 - Two hoist: 4.25" ID, 3.0" rod, (108 mm x 76 mm), 53.43" (1357 mm) stroke
 - One telescope: 4.5" ID, 3.25" rod, (127 mm x 83 mm) 13'6" (3.94 m) stroke

Four Hydraulic Motors

- Swing, 68 hp (51 kW)
- Tilt, 28 hp (21 kW)
- Two propel motors, 120 hp (89 kw) each

Operating Pressures

- Hoist..... 4,900 psi(331 BAR)
- Tilt 2,400 psi(165 BAR)
- Swing 4,500 psi(310 BAR)
- Tool 4,900 psi(331 BAR)
- Telescope 3,300 psi(228 BAR)
- Propel..... 4,900 psi(331 BAR)
- Pilot System 550 psi (38 BAR)

Oil Capacity

- System 95 gallon (360 L)
- Pressurized reservoir with visual oil level gauges

Filtration System

- 10 micron return filter
- 10 micron pilot filter
- Fin and tube-type oil cooler with thermal by-pass and relief valves
- Pressure-compensated, load-sensing valves with circuit reliefs in all circuits

Crawler Drive

- Dual range, high torque piston motor powers each track
- Planetary crawler drive with integral park brake

Travel speed on flat, level surface

- High Speed 2.0 mph (3.2 km/h)
- Low Speed 1.0 mph (1.6 km/h)

- Automatic two-speed control shifts crawler drive into low speed under difficult travel conditions
- Manual override selector switch to lock travel in low speed

Gradeability

- 88%, limited by engine lubrication requirements

Drawbar Pull

- 65,205 lbs (290 kN)

Track Width: 31.5" (800 mm)

Track Length: (sprocket - idler) 149.5" (3795 mm)

Average Ground Pressure:

8.18 psi (0.58 kg/cm²)

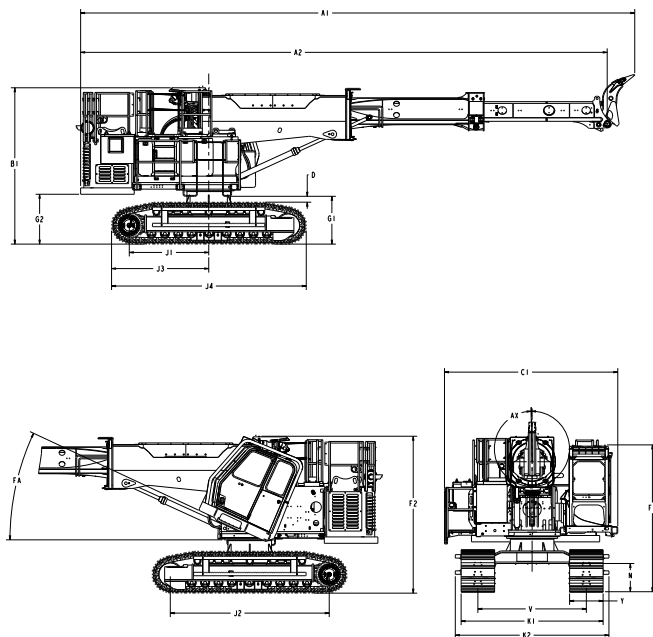
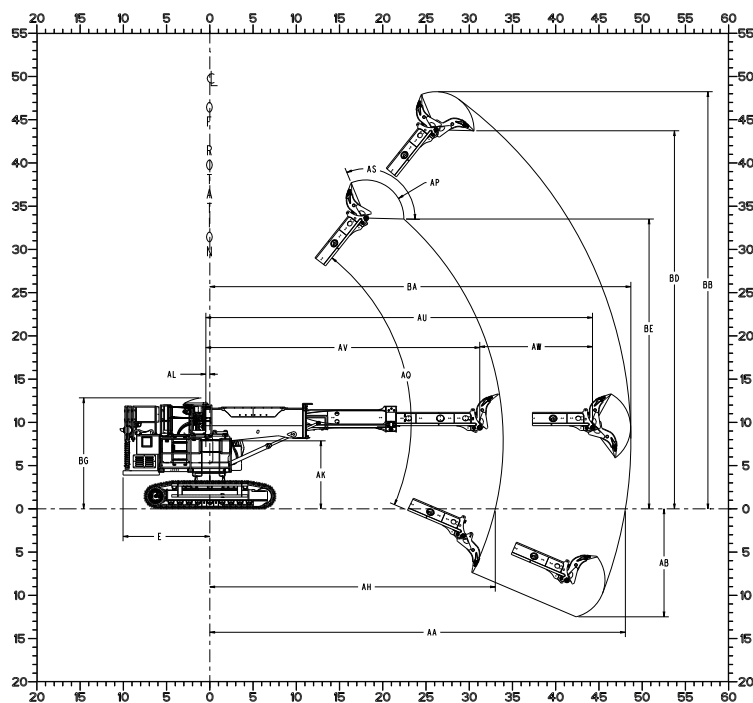

Dimensions

- | | | |
|--|--|--|
| <p>A1 Overall length (boom level) with scaling hook: 43' 5" (13.2)</p> <p>A2 Overall length (boom level) without scaling hook: 41' 3" (12.6)</p> <p>B1 Overall height (boom level): 12' 3" (3.7)</p> <p>C1 Width of upperstructure: 13' 6" (4.1)</p> <p>D Minimum clearance, upperstructure to undercarriage: 5" (127 mm)</p> <p>E Swing clearance, rear of upperstructure: 10' 0" (3.0)</p> <p>F1 Top of cab guard to groundline (cab level): 11' 6" (3.5)</p> <p>F2 Top of cab guard to groundline (cab at full tilt): 12' 3" (3.7)</p> <p>FA Cab tilt: 25°</p> <p>G1 Clearance, upperstructure to groundline: 3' 9" (1.1)</p> <p>G2 Clearance, counterweight to groundline: 3' 11" (1.2)</p> <p>J1 Axis of rotation to centerline of drive sprockets: 6' 2" (1.9)</p> | <p>J2 Nominal distance between centerlines of drive sprockets and idlers: 12' 6" (3.8)</p> <p>J3 Axis of rotation to end of track assembly: 7' 7" (2.3)</p> <p>J4 Nominal overall length of track assembly: 15' 3" (4.6)</p> <p>K1 Width of chassis, outside of tracks: 11' 1" (3.4)</p> <p>K2 Width of chassis, outside of steps: 12' 0" (4.1)</p> <p>N Ground clearance: 2' 3" (700 mm)</p> <p>V Track gauge, roller centerline to roller centerline: 8' 6" (2.6)</p> <p>Y Width of crawler track assembly: 31.5" (800 mm)</p> <p>AA Maximum radius at groundline: 48' 0" (14.6)</p> <p>AB Maximum depth: 12' 5" (3.8)</p> <p>AH Minimum radius at groundline: 33' 0" (10.1)</p> <p>AK Boom pivot to groundline: 7' 10" (2.4)</p> <p>AL Boom pivot to axis of rotation: 6" (140 mm)</p> <p>AP Scaling hook tooth radius: 4' 5" (1.3)</p> | <p>AQ Boom pivot angle: 52° Up & 23° Down</p> <p>AS Attachment pivot angle: 114°</p> <p>AU Maximum telescoping boom length (boom pivot to attachment pivot): 44' 9" (13.6)</p> <p>AV Minimum telescoping boom length (boom pivot to attachment pivot): 31' 8" (9.6)</p> <p>AW Telescoping boom travel: 13' 1" (4.0)</p> <p>AX Boom tilt angle (continuous): 360°</p> <p>BA Maximum radius of working equipment: 48' 8" (14.8)</p> <p>BB Maximum height of working equipment: 48' 2" (14.7)</p> <p>BD Minimum clearance of scaling tooth, with attachment at maximum height: 43' 8" (13.3)</p> <p>BE Minimum clearance of scaling tooth at minimum boom height: 33' 6" (10.2)</p> <p>BG Maximum height of working equipment, with boom below groundline: 12' 10" (3.9)</p> |
|--|--|--|

Specifications subject to change without notice.
Metric units are meters (m) unless noted.
Machines shown may have optional equipment.

Swing

- Priority swing circuit with axial piston motor
- Planetary transmission

Swing speed: 7.0 rpm

Swing Brake

- Automatic spring-set/hydraulic release wet-disc parking brake
- Dynamic braking provided by hydraulic system

Weight

- Approximate working weight with hammer, fuel tank half full and no operator

Pad Size	Weight	Bearing Pressure
31.5" 800 mm	77,500 lbs (35,153 kg)	11.4 psi (78.6 kPa)

Function Forces

Rated Boom In: 23,210 lbs (103 kN)

Rated Boom Out: 27,357 lbs (122 kN)

Rated Ripper Tooth Force: 19,888 lbs (89 kN)

Boom Rotating Torque: 18,375 ft lb (24913 Nm)

Boom Rotating Speed: 5.3 rpm

It is Gradall Policy to continually improve its products. Therefore designs, materials and specifications are subject to change without notice and without incurring any liability on units already sold. Units shown may have optional equipment.

GRADALL®

406 Mill Ave. SW, New Philadelphia, Ohio 44663
Phone: 800-445-4752
www.Gradall.com



Form No. 11839 4/26
Printed in USA