

GRADALL[®] XL 4210 V

STEEL MILL MAINTENANCE



SPECIFICATIONS

Engine

- Volvo TAD581VE, Stage 5, 5.1L diesel with SCR and DPF + DOC and uncooled EGR
- Gross Rating:** 172 hp @ 2000 rpm (128kW)
590 lb-ft @ 1100-1500 rpm (800Nm)
- Net Rating:** 152 hp @ 2000 rpm (113kW)
- Four cycle, inline four cylinder, liquid cooled
- Variable viscous fan clutch system
- Vertical stacked hydraulic oil cooler, charge air cooler and radiator
- Vertical canister style lube filter attached to engine
- Vertical canister style main fuel filter and fuel/water separation with manual feed pump attached to engine
- Water in fuel indicator and alarm
- Block heater

Maximum slope: 30°

- 24 volt starter
- 100 amp alternator
- Two SAE #C31-S 1000 CCA batteries
- Two-stage dry type air cleaner with centrifugal pre-cleaner and safety element
- Vacuumer valve and service indicator

Fuel tank capacity: 82 gallons (310 L)

Operator Cab

- All-weather cab
- Tinted safety glass windows
- Acoustical lining
- Four-way adjustable seat
- AM/FM radio
- Filtered fresh air heater
- Defroster
- Air conditioner
- Front window has heat-resistant glass
- Rearview mirrors on right and left sides
- Swing lights

Controls

- Two electronic joysticks (hoist and bucket, telescope and swing)
- One rocker switch (tilt) control
- Joysticks mounted on arm pods
- Quick change joystick pattern switch located on instrument panel
- Self-centering joysticks; when controls are released, power for movement disengages and swing and tilt brake set automatically

- Two electric foot pedals (with handles) control crawler travel speed and direction, crawler steering and crawler brakes
- Toggle switch on arm pod allows selection of two crawler speed ranges

Engine Controls and Instrumentation

- Key operated ignition/starter switch, throttle and main battery disconnect switch
- Air cleaner condition indicator
- Electronic monitor indicates fuel level, low battery charge, lube oil pressure, high coolant temperature, engine rpm and engine hours
- Fuel saving auto idle feature sends engine rpm to idle when control circuits are in neutral for seven seconds

Boom

- Two piece triangular telescoping boom
- Adjustable boom rollers with eccentric shafts
- 360° continuous boom tilt
- 105° boom pivot angle
- Auxiliary hydraulics

Hydraulic System

Pumps

- One load-sensing, axial piston pump; oil flow 0-110 gpm (0-435 L/min)
- Gear pump, 6 gpm (23 L/min)

System Monitor

- Electronic monitor in cab indicates
 - Low hydraulic fluid level
 - High hydraulic fluid temperature
 - System working pressure
 - System pilot pressure

SYSTEM SPECIFICATIONS

Four Cylinders

- One tool: 5.0" ID, 3.0" rod (127 mm x 76 mm), 25.9" (658 mm) stroke
- Two hoist: 4.25" ID, 3.15" rod (108 mm x 80 mm), 31.0" (787 mm) stroke
- One telescope: 3.5" ID, 2.559" rod (89 mm x 65 mm), 12'6" (3.81 m) stroke

Four Hydraulic Motors

- Swing, 64 hp (48 kW)
- Tilt, 50 hp (37 kW)
- Two propel motors, 120 hp (89 kW) each

Operating Pressures:

- Hoist..... 4,900 psi(331 BAR)
- Tilt 4,900 psi(331 BAR)
- Swing 4,200 psi(290 BAR)
- Tool 4,900 psi(331 BAR)
- Telescope 4,900 psi(331 BAR)
- Propel..... 4,900 psi(331 BAR)
- Pilot System 550 psi (38 BAR)

Oil Capacity

- Reservoir system 65 gallons (246 L)
- Pressurized reservoir with visual oil level gauges

Filtration System

- 10 micron return filter
- 10 micron pilot filter
- Fin and tube-type oil cooler with thermal by-pass and relief valves
- Pressure-compensated, load-sensing valves with circuit reliefs in all circuits

Crawler Drive

- Dual range, high torque piston motor powers each track
- Three-stage planetary drive with integral speed limiting valve and automatic spring-set/hydraulic release wet-disc parking brake

Travel Speed: on flat, level surface:

- High Speed: 3.4 mph (5.5 km/h)
- Low Speed: 1.9 mph (3.1 km/h)

- Automatic two-speed control shifts crawler drive into low speed under difficult travel conditions
- Manual override switch for loading the machine for transport

Gradeability:

- 58%, limited by engine lubrication requirements

Drawbar Pull

- 38,324 lbs (170 kN)

Individual Track Control

- Tracks counter-rotate to pivot machine about the swing centerline
- Electronically operated travel alarm signals crawler movement in either direction

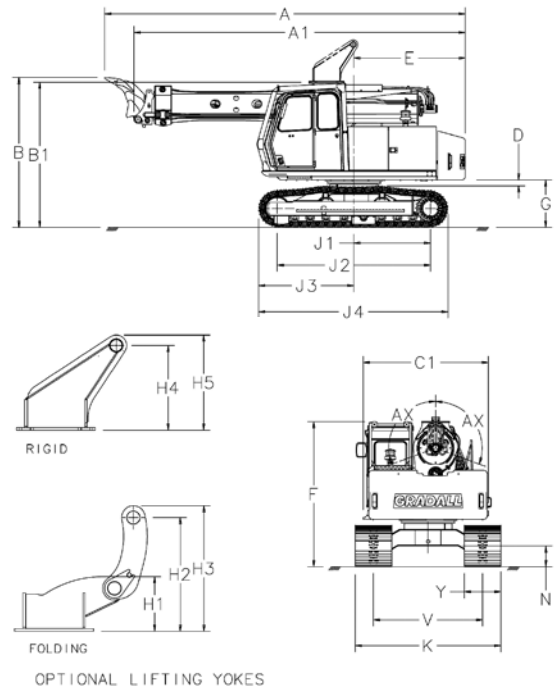
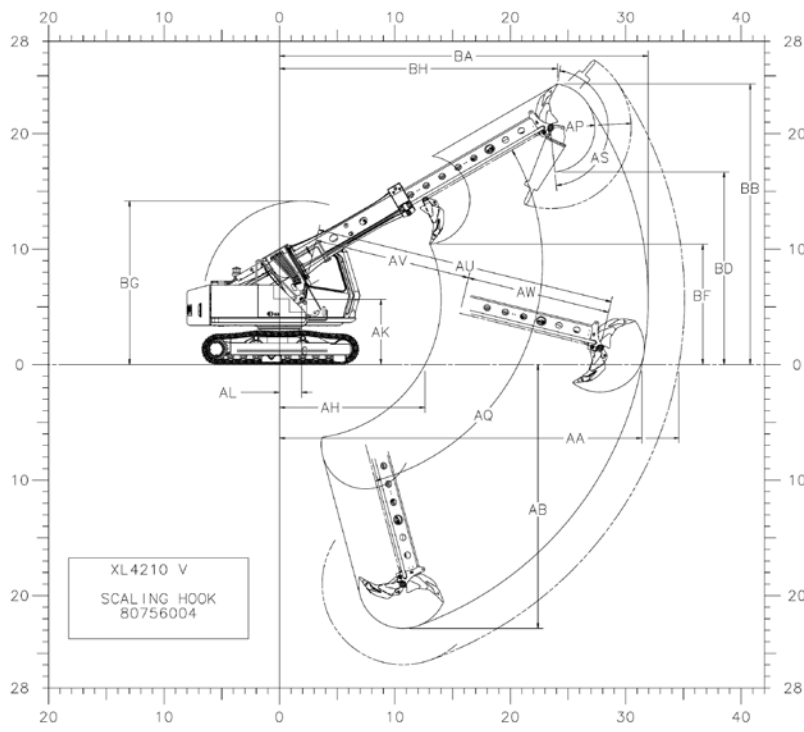

Dimensions

- | | | |
|---|---|--|
| A Overall length with attachment open: 25'11" (7.9) | J3 Axis of rotation to end of track assembly: 6'10" (2.1) | AP Attachment tooth radius (Scaling Hook): 3'10" (1.2)
Attachment bit radius (S-29 Hammer): 7'0" (2.1) |
| A1 Overall length without attachment: 23'10" (7.3) | J4 Nominal overall length of track assembly: 13'8" (4.2) | AQ Boom pivot angle: 30° Up and 75° Down |
| B Overall height with attachment open: 10'9" (3.3) | K Width of crawler (standard): 10'6" (3.2)
Width of crawler (optional): 9'10" (3.0) | AS Attachment pivot angle: 165° |
| B1 Overall height without attachment: 10'5" (3.2) | N Ground clearance (per SAE J1234): 18" (454 mm) | AU Maximum telescoping boom length
(boom pivot to attachment pivot): 26'1" (8.0) |
| C1 Width of upperstructure: 9'0" (2.7) | V Track gauge, roller centerline to roller centerline:
7'10" (2.4) | AV Minimum telescoping boom length
(boom pivot to attachment pivot): 13'7" (4.1) |
| D Minimum clearance, upperstructure to undercarriage: 5" (130 mm) | Y Width of crawler track assembly (standard):
31'5" (800 mm)
Width of crawler track assembly (optional):
23'6" (600 mm) | AW Telescoping boom travel: 12'6" (3.8) |
| E Swing clearance, rear of upperstructure: 8'0" (2.4) | AA Maximum radius at groundline (Scaling Hook):
31'5" (9.6)
Maximum radius at groundline (S-29 Hammer):
34'7" (10.5) | AX Boom tilt angle (continuous): 360° |
| F Top of cab guard to groundline: 10'5" (3.2) | AB Maximum depth: 22'10" (7.0) | BA Maximum radius of working equipment: 31'11" (9.7) |
| G Clearance, upperstructure to groundline: 3'5" (1.0) | AH Minimum radius at groundline: 12'7" (3.8) | BB Maximum height of working equipment: 24'4" (7.4) |
| H1 Height of optional folding lift yoke lowered: 1'9" (0.5) | AK Boom pivot to groundline: 5'8" (1.7) | BD Minimum clearance of attachment with pivot at maximum height: 16'8" (5.1) |
| H2 Height of pin of optional folding lift yoke: 3'7" (1.1) | AL Boom pivot to axis of rotation: 1'11" (585 mm) | BF Minimum clearance of attachment at maximum boom height: 10'5" (3.2) |
| H3 Overall height of optional folding lift yoke: 4'0" (1.2) | | BG Maximum height of working equipment with attachment below groundline: 14'2" (4.3) |
| H4 Height to pin of optional rigid lift yoke: 2'8" (0.8) | | BH Radius of attachment tooth at maximum height: 24'1" (7.3) |
| H5 Overall height of optional rigid lift yoke: 3'0" (0.9) | | |
| J1 Axis of rotation to centerline of drive sprockets: 5'1" (1.7) | | |
| J2 Nominal distance between centerlines of drive sprockets and idlers: 11'0" (3.4) | | |

Specifications subject to change without notice.
Metric units are meters (m) unless noted.
Machines shown may have optional equipment.

Swing

- Priority swing circuit with axial piston motor
- Planetary transmission

Swing speed: 7.0 rpm

Swing Brake

- Automatic spring-set/hydraulic release wet-disc parking brake
- Dynamic braking is provided by the hydraulic system

Weight

- Approximate working weight with hammer, fuel tank half full and no operator

Pad Size	Weight	Bearing Pressure
31.5" 800 mm	48,862 lbs (22,163 kg)	5.8 psi (40.2 kPa)

It is Gradall Policy to continually improve its products. Therefore designs, materials and specifications are subject to change without notice and without incurring any liability on units already sold. Units shown may have optional equipment.

GRADALL®

406 Mill Ave. SW, New Philadelphia, Ohio 44663
Phone: 800-445-4752
www.Gradall.com



Form No. 11837 4/26
Printed in USA

Function Forces

Rated Boom Force: 22,075 lbs (98.2 kN)

Rated Ripper Tooth Force: 25,405 lbs (113 kN)

Boom Rotating Torque: 25,800 ft lb (34,980 Nm)

Boom Rotating Speed: 7.0 rpm